











EWV1201YF

Production

Features

-  Dual Output Frequencies
-  Push-push Architecture
-  Phase Noise: -110 dBc/Hz @ 100 kHz
-  Output Power at f_{out} : +10 dBm, typical
-  Output Power at $f_{out/2}$: +12 dBm, typical
-  Integrated Divide by 2 Prescaler
-  HBM Class 1A - ESD Protection Bias Circuitry
-  Package: 5 x 5 mm, 32 Lead, plastic overmold QFN
-  100% RF and DC tested
-  Also available in bare die format
-  RoHS Compliant

Device Photo

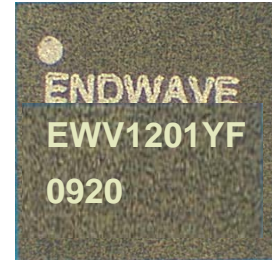

Description

The Endwave *EWV1201YF* is a high performance InGaP/GaAs HBT MMIC voltage controlled oscillator which provides a set of dual outputs ideal for applications which require 5.5 to 6.1 or 11.0 to 12.2 GHz outputs. The device boasts state of the art phase noise at better than -110 dBc/Hz at a 100 kHz offset. This device has integrated ESD protection bias circuitry and can be used for a wide range of applications from defense electronics to commercial communication systems. All parts are 100% DC and RF tested and visually inspected to IPC-A-610.

Functional Diagram

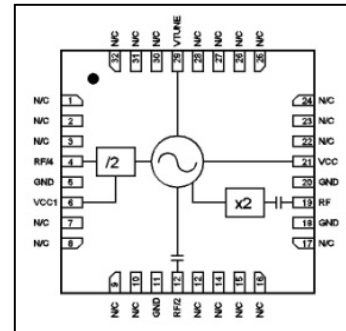

Electrical Characteristics (Temperature = +25 °C, $V_{cc}=+5$)

Parameter	Min.	Typ.	Max.	Units
Frequency Range (f_{out})	11.0		12.2	GHz
Frequency Range ($f_{out/2}$)	5.5		6.1	GHz
Output Power (f_{out})	+7	+10	+14	dBm
Output Power ($f_{out/2}$)	+8	+12	+14	dBm
Output Power ($f_{out/4}$)	-3	+1	+3	dBm
Phase Noise @ f_{out} 100 kHz Offset, $V_t = +5V$		-110		dBc/Hz
Tune Voltage	2		13	V
Supply Current				
VCO	230	260	290	mA
Prescaler (optional)	35	45	55	mA
Tune Port Leakage Current, $V_{tune} = 13V$			10	uA
Output Return Loss		5		dB
Harmonic / Subharmonics				
$\frac{1}{2}$		23		dBc
2^{nd}		8		dBc
Pulling (into a 2:1 VSWR)		5		MHz pp
Pushing @ $V_{tune} = 5V$		5		MHz/V
Frequency Drift Rate			-1.0	MHz/ C

RF Frequency vs. Tuning Voltage, $V_{cc} = 5V$

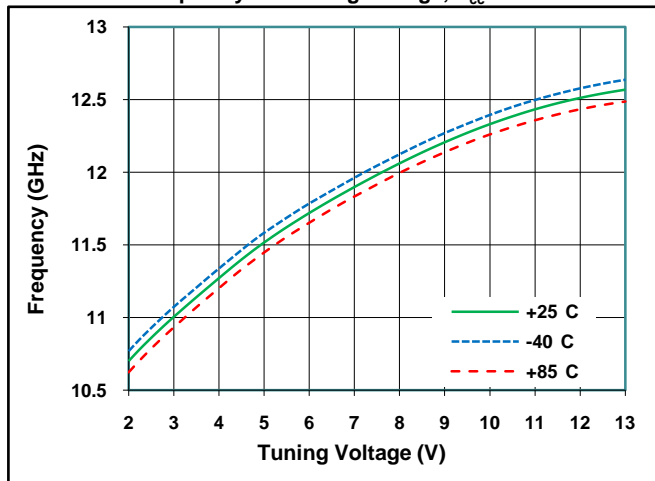

RF Sensitivity vs. Tuning Voltage, $V_{cc} = 5V$

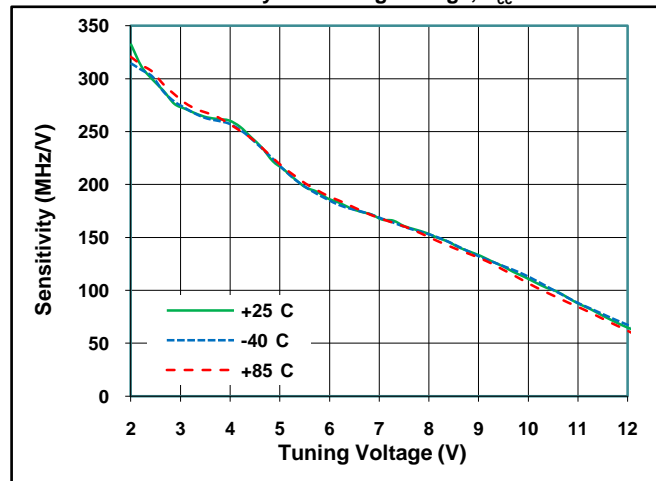

RF Output Power vs. Tuning Voltage, $V_{cc} = 5V$

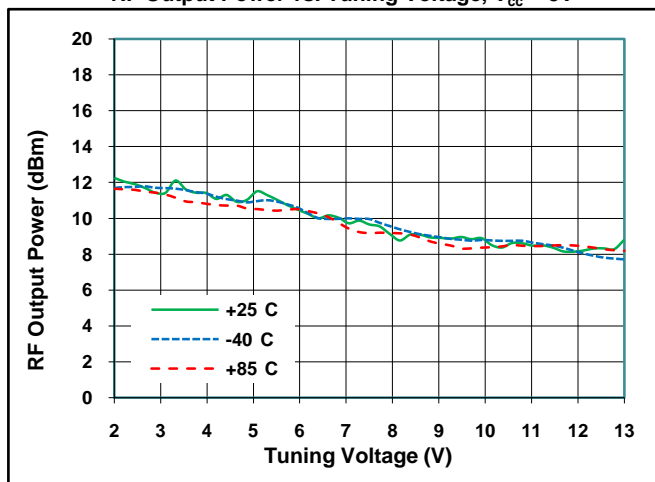

RF/2 Output Power vs. Tuning Voltage, $V_{cc} = 5V$

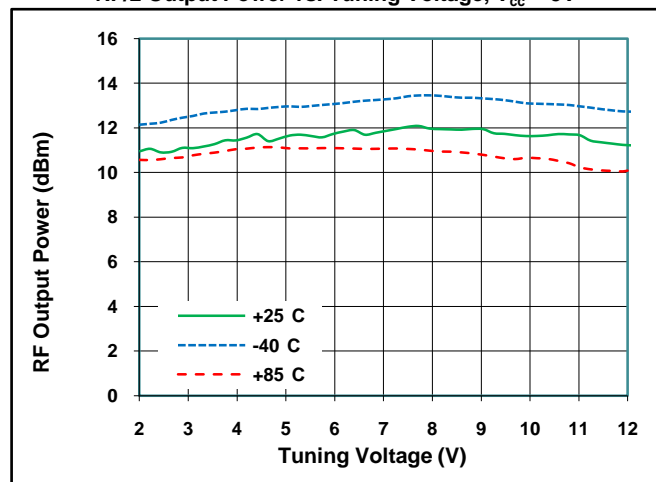

SSB Phase Noise @ RF Output vs. Tuning Voltage

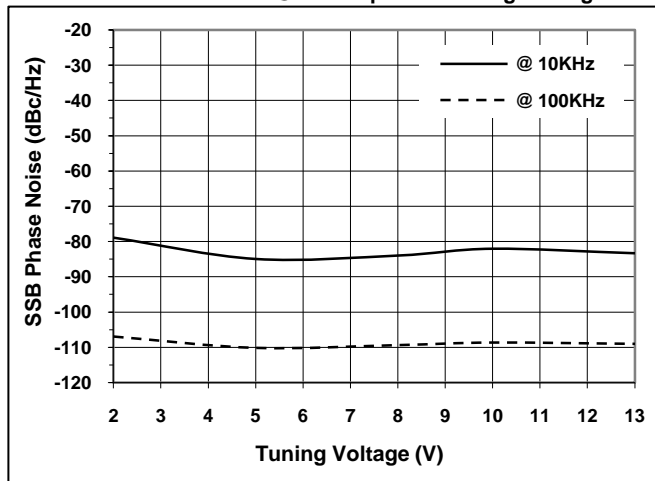

SSB Phase Noise @ RF Output / $V_{tune} = 8V$

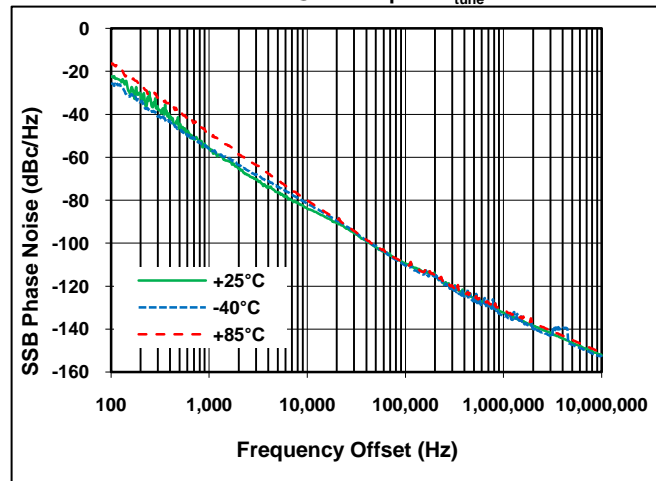

DC & RF Pinout

Pin Number	Function
1-3, 7-10, 13-17, 22-28, 30-32	No Connection
5, 11, 18, 20	Ground (or no connection)
19	RF Output (f_{out})
12	RF/2 Output ($f_{out/2}$) ^{Note 1}
4	RF/4 Output ($f_{out/4}$) ^{Note 2}
6	V_{cc1} for Prescaler
21	V_{cc} for VCO
29	V_{tune}

Note 1 It is recommended that RF/2 Output be terminated with a 50 ohm load if not used.

Note 2 DC block must be used at RF/4 output port. 100pf 0402 capacitor is used on ENWV eval boards.

Outline Drawings

"F" Package – 5 x 5mm, 32 lead

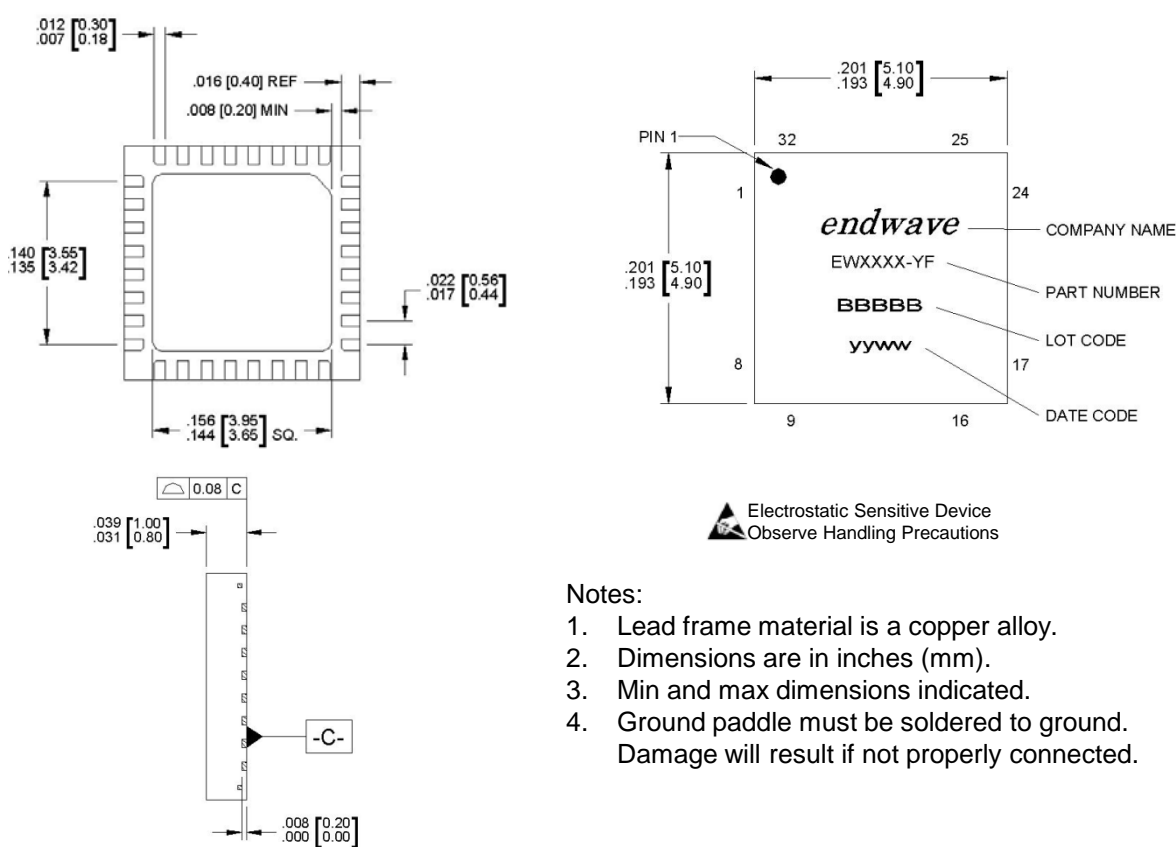

The drawings show the following dimensions and features:

- Top View:** Overall size 0.140 [3.55] x 0.135 [3.42] inches. Lead pitch 0.012 [0.30] / 0.007 [0.18] inches. Lead width 0.016 [0.40] REF and 0.008 [0.20] MIN. Lead length 0.156 [3.95] / 0.144 [3.65] SQ. Lead thickness 0.022 [0.56] / 0.017 [0.44] inches. Pin 1 location 0.201 [5.10] / 0.193 [4.90] inches from the top-left corner.
- Side View:** Lead height 0.039 [1.00] / 0.031 [0.80] inches. Lead thickness 0.008 [0.20] / 0.000 [0.00] inches.
- Lead View:** Lead thickness 0.008 [0.20] / 0.000 [0.00] inches.
- Marking:** The top surface of the package is marked with "endwave" (COMPANY NAME), "EWXXXX-YF" (PART NUMBER), "BBBBB" (LOT CODE), and "yyww" (DATE CODE).

Electrostatic Sensitive Device
Observe Handling Precautions

Notes:

- Lead frame material is a copper alloy.
- Dimensions are in inches (mm).
- Min and max dimensions indicated.
- Ground paddle must be soldered to ground. Damage will result if not properly connected.

Voltage Controlled Oscillators

Absolute Maximum Ratings

Supply Voltage, V_{cc}	+5.5V
Tune Voltage, V_t	+0 to +15 V
Channel Temperature	135°C
Continuous Power Dissipation at 25°C	1.32 W
Supply Current, VCO	330 mA
Supply Current, Prescaler	60 mA
Storage Temperature	-65 to +150°C
Operating Temperature	-40 to +85°C

Typical Supply Current

V_{cc}	I_{cc}
4.8 V	237 mA
5.0 V	260 mA
5.2 V	283 mA

Typical Application

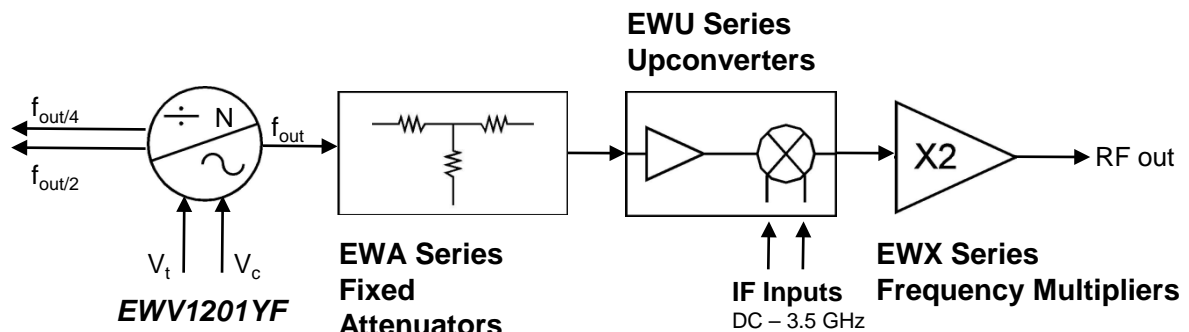

Support Documentation

Support documentation including Assembly Notes, Application Notes, And Qualification Procedures can be found on our website at www.endwave.com.

Ordering Information

Part Number	Description
<i>EWV1201YF</i>	RoHS compliant, 5 x 5mm, 32 lead, QFN "F" Package
<i>EWV1201YF-EV</i>	<i>EWV1201YF</i> on an Evaluation Board
<i>EWV1201ZZ</i>	RoHS compliant bare die in waffle or gel packs
<i>EWV1201ZZ-EV</i>	<i>EWV1201ZZ</i> in a connectorized test fixture

Voltage Controlled Oscillators