







EWA4001ZZ

Features

-  Broadband Performance: 18 to 40 GHz
-  Dynamic Range: 22 dB, typical
-  Input IP3: +20 dBm, typical
-  Dual Voltage Control: -1.5 to 0 V
-  100% RF and DC tested
-  Die Size: 1.5 x 1.5 x 0.1mm
-  RoHS Compliant

Device Photo

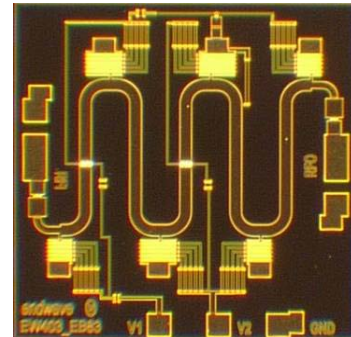

Description

The Endwave *EWA4001ZZ* is a GaAs pHEMT broadband voltage variable attenuator MMIC. The high linearity voltage variable attenuator provides 22 dB dynamic range with +20 dBm input IP3 at any attenuation. This device can be used for a wide range of applications from defense electronics to commercial communication systems. All die are 100% DC and RF tested and visually inspected to Mil-Std-883 Method 2010.

Block Diagram

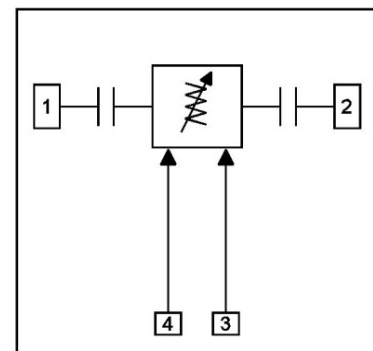

Electrical Characteristics (Temperature = +25 °C)

Parameter	Min.	Typ.	Max.	Units
Frequency Range	18		40	GHz
Minimum Insertion Loss	1.6		3.7	dB
Dynamic Range @ 18 GHz		22		dB
Input Return Loss (over dynamic range)		7		dB
Output Return Loss (over dynamic range)		8		dB
Input IP3 (any attenuation)		20		dBm
Gain control Voltage ¹ (Vctrl 1,2)	-1.5		0	V

Note 1: Max attenuation for Vctrl 1, 2 = 0 volts

EWA4001ZZ

Voltage Variable Attenuator - Bare Die

**Attenuation vs. Frequency
18 - 40 GHz**

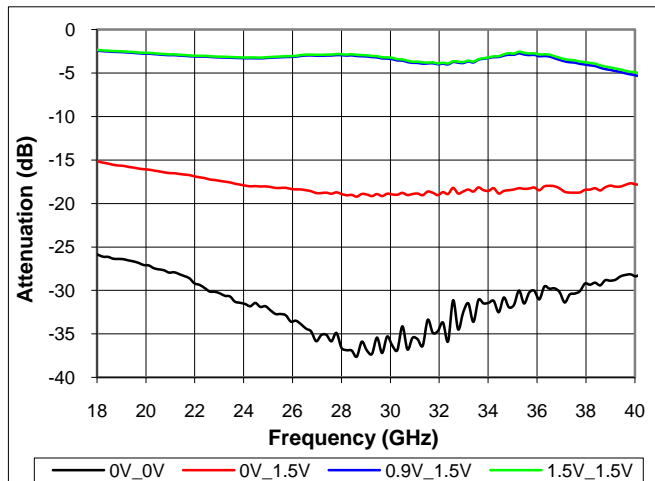

**Return Loss vs. Frequency
18 - 40 GHz**

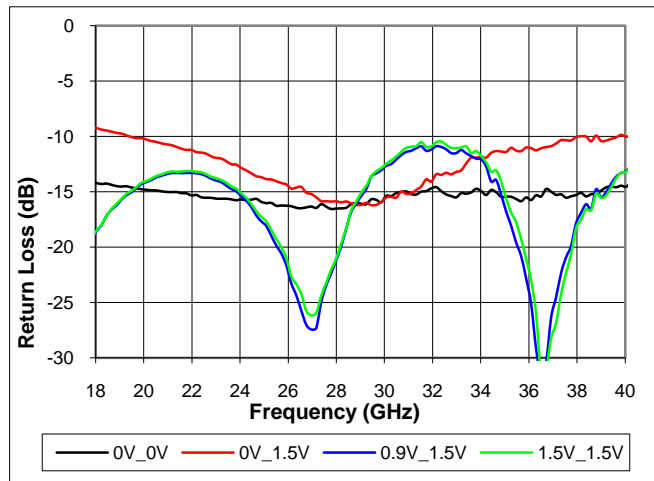

**Attenuation vs. Frequency
36 - 40 GHz**

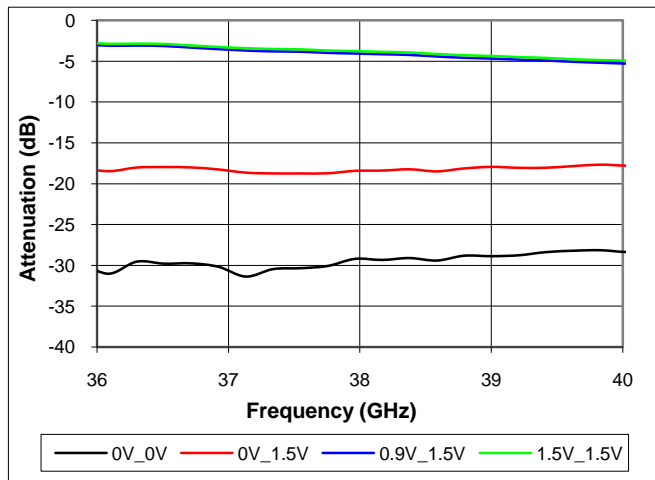

**Return Loss vs. Frequency
36 - 40 GHz**

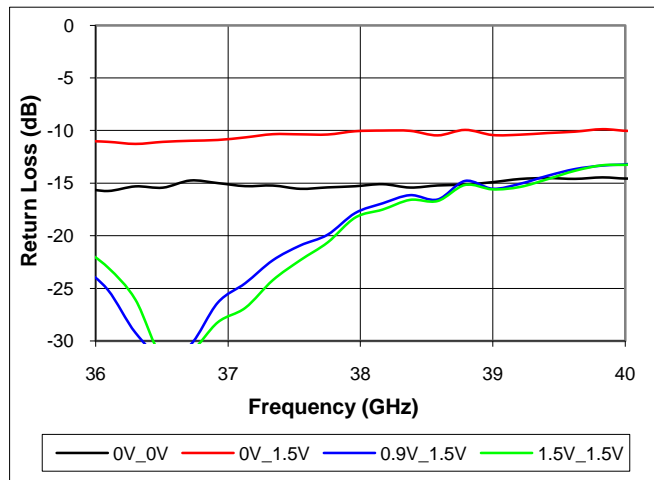

**Attenuation vs. Frequency
30 - 34 GHz**

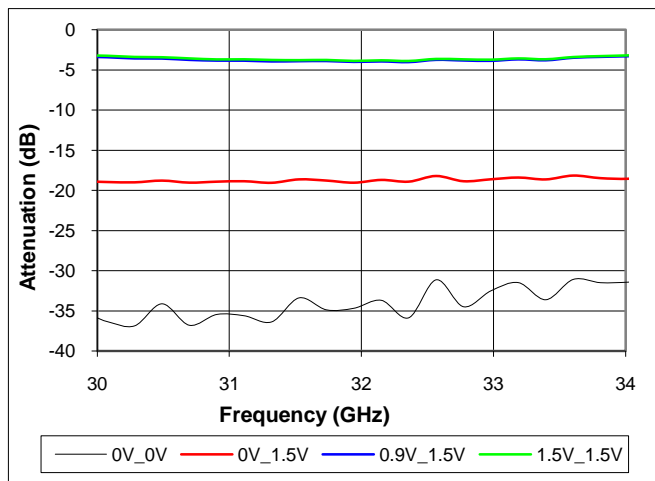

**Return Loss vs. Frequency
30 - 34 GHz**

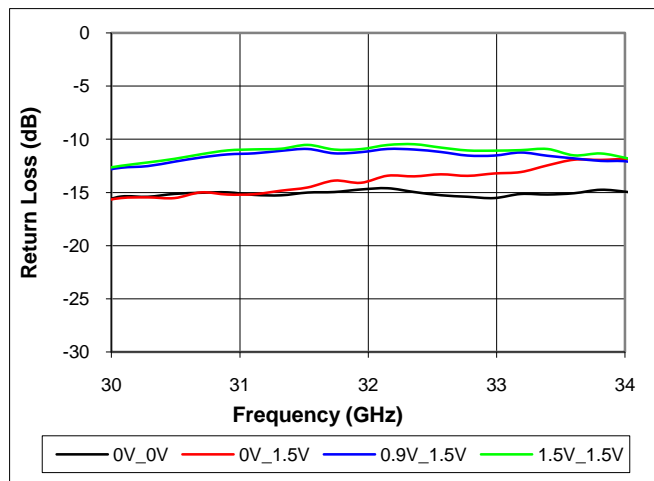

EWA4001ZZ

Voltage Variable Attenuator – Bare Die

**Attenuation vs. Frequency
26 – 30 GHz**

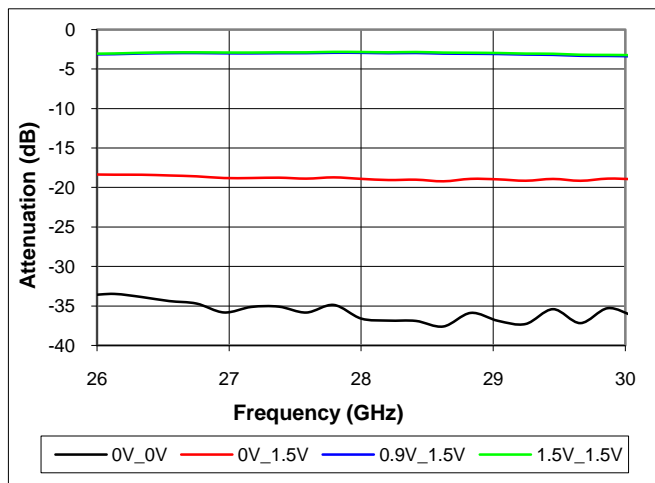

**Return Loss vs. Frequency
26 – 30 GHz**

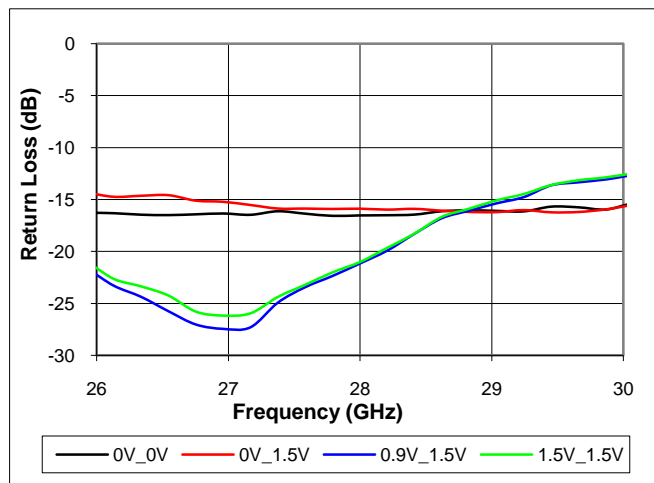

**Attenuation vs. Frequency
24 – 28 GHz**

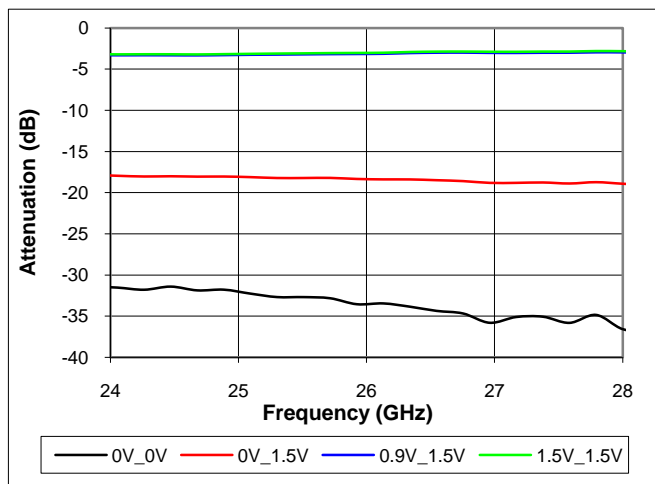

**Return Loss vs. Frequency
24 – 28 GHz**

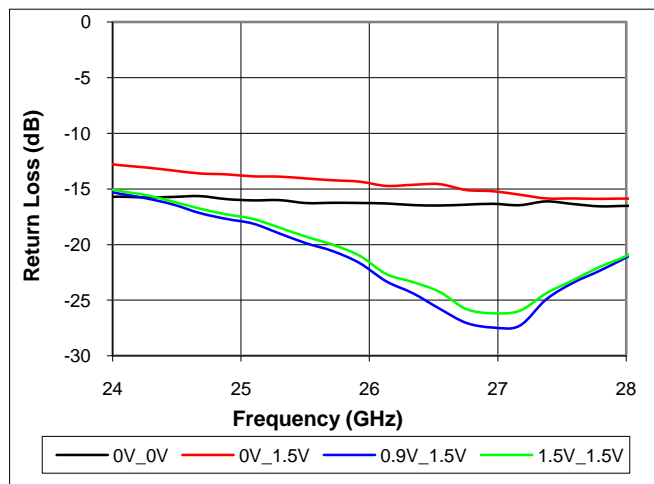

**Attenuation vs. Frequency
21 – 25 GHz**

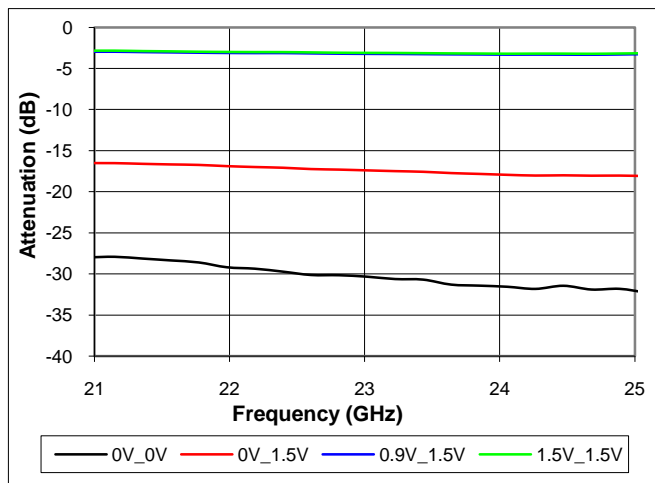

**Return Loss vs. Frequency
21 – 25 GHz**

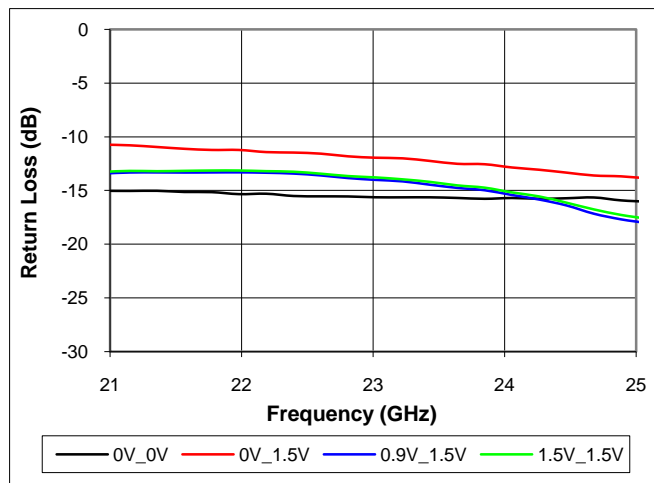

Input IP3 vs. V2 (V1 = -1.5)

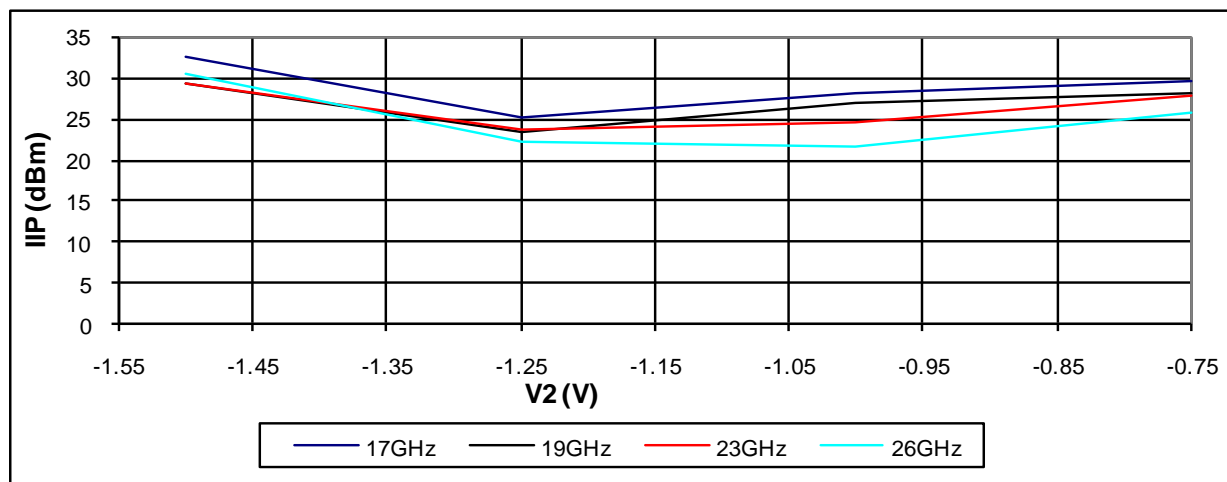

Input IP3 vs. V1 (V2 = -1.5)

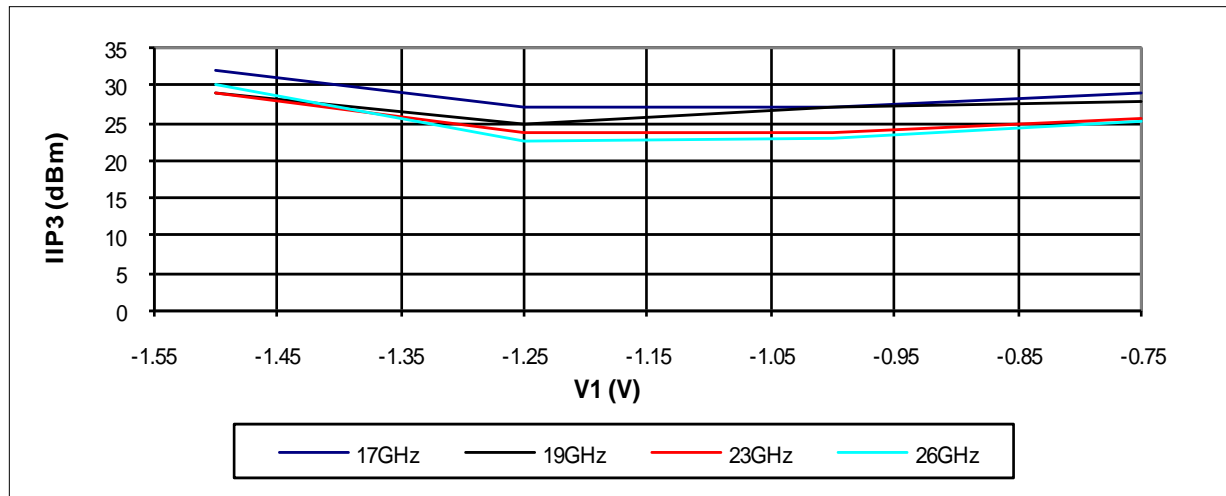

Input IP3 vs. V2 & V1

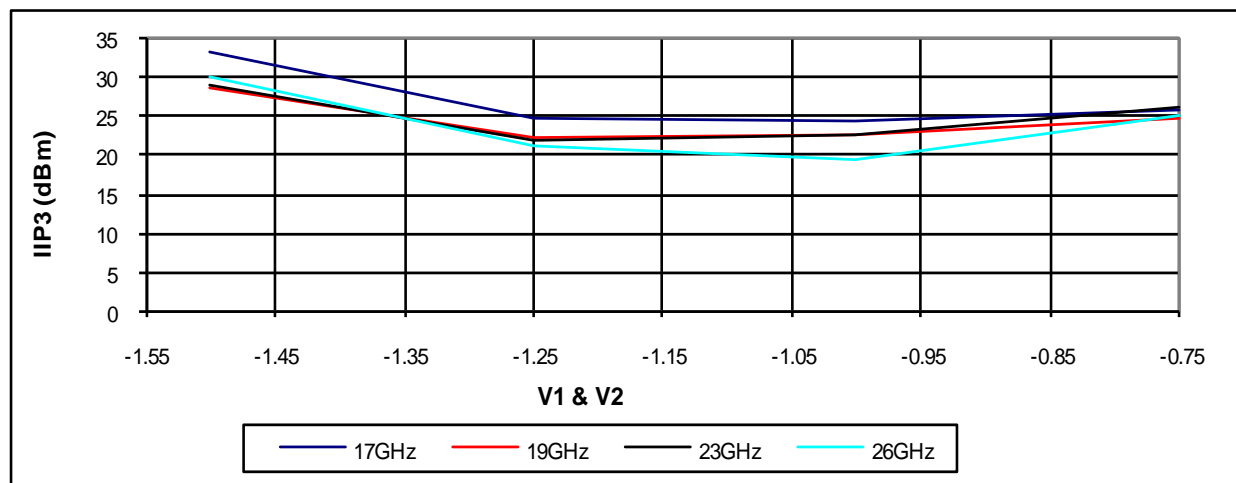

Assembly Drawing

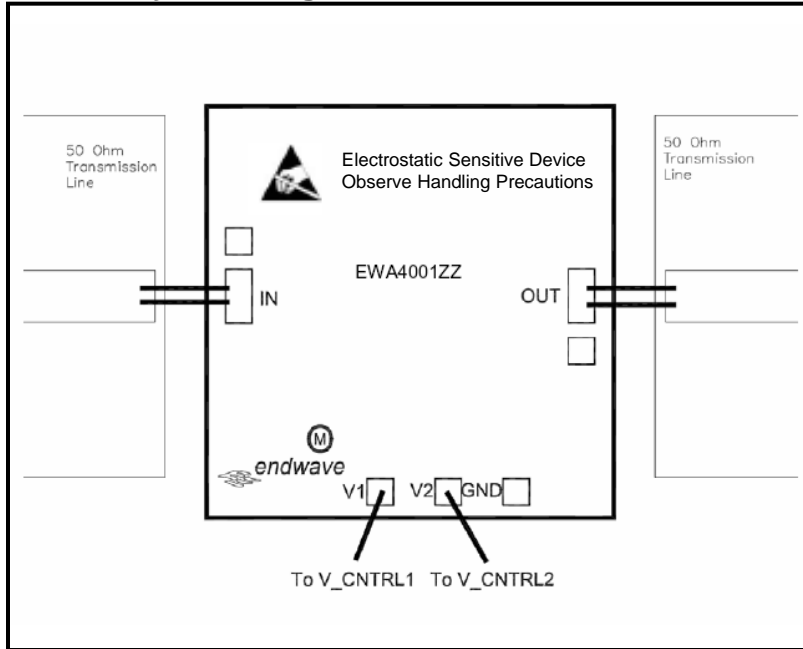

Outline Drawing

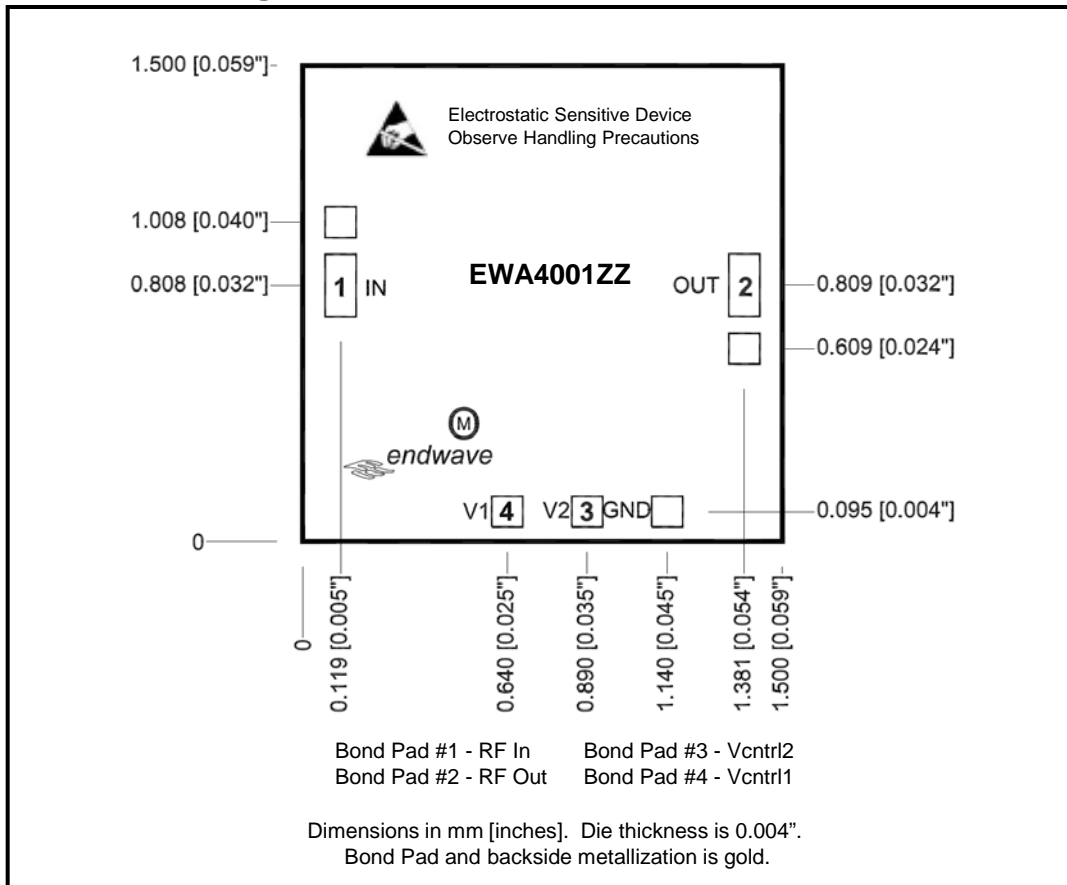

Absolute Maximum Ratings

RF Input Power (min attenuation)	+25 dBm
Control Voltage (Vctrl1, 2)	-2.5 V to 0V
Storage Temperature	-65 to +150°C
Operating Temperature	-40 to +85°C

Typical Application

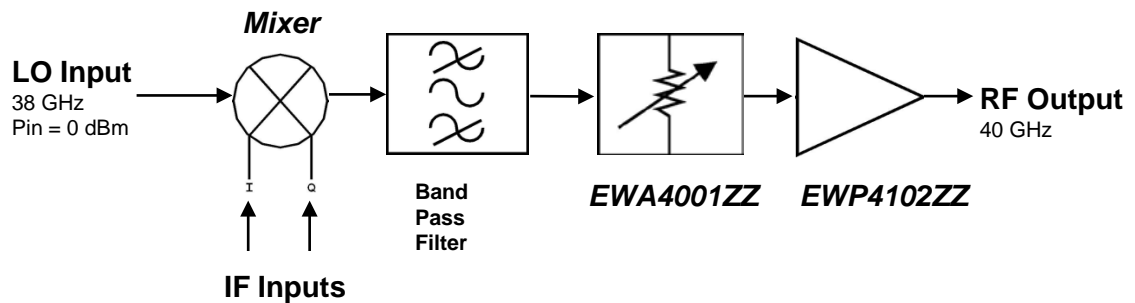

Support Documentation

Support documentation including Assembly Notes, Application Notes and Qualification Procedures can be found on our website at www.endwave.com.

Ordering Information

Part Number	Description
EWA4001ZZ	RoHS compliant bare die in wafer or gel packs
EWA4001ZZ-EV	EWA4001ZZ in a connectorized test fixture